

G SERIES SHEAR WRENCH

GM-161EZ / GM-162EZ

Model	GM-161EZ	GM-162EZ
Frequency	50-60Hz	
Rated Voltage(Single Phase)	115V	230V
Max. Current	10A	5A
Rated Input Power	1100W	
Intermittent Operation (rated operating time / rated resting time)	2s/3s	
Rated Max. Torque	294N.m (217lbf.ft)	
No-Load Speed	29min ⁻¹ (rpm)	
Sound Pressure Level	87dB(A)	
Acoustic Power Level	98dB(A)	
Vibration Level	2.5m/s ² or below	
Adaptable Bolts Dia.	S10T	M12, M16
	A325	5/8"
	A490	5/8"
Weight (Main Body)	3.7kg(8.1lbs)	
Protection Class	□ (class II tool)	

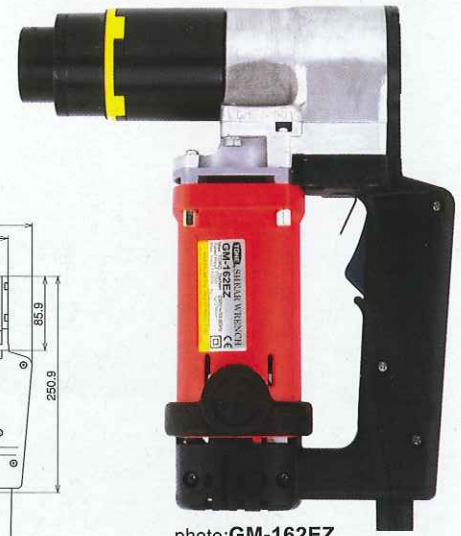
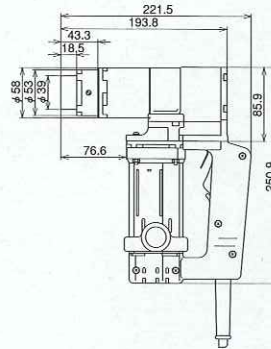

photo:GM-162EZ

GM-221EZ / GM-222EZ

Model	GM-221EZ	GM-222EZ
Frequency	50-60Hz	
Rated Voltage(Single Phase)	115V	230V
Max. Current	11A	5.5A
Rated Input Power	1200W	
Intermittent Operation (rated operating time / rated resting time)	2s/3s	
Rated Max. Torque	735N.m (542lbf.ft)	
No-Load Speed	14min ⁻¹ (rpm)	
Sound Pressure Level	87dB(A)	
Acoustic Power Level	98dB(A)	
Vibration Level	2.5m/s ² or below	
Adaptable Bolts Dia.	S10T	M16, M20, M22
	A325	5/8", 3/4", 7/8"
	A490	5/8", 3/4"
Weight (Main Body)	4.8kg(10.6lbs)	
Protection Class	□ (class II tool)	

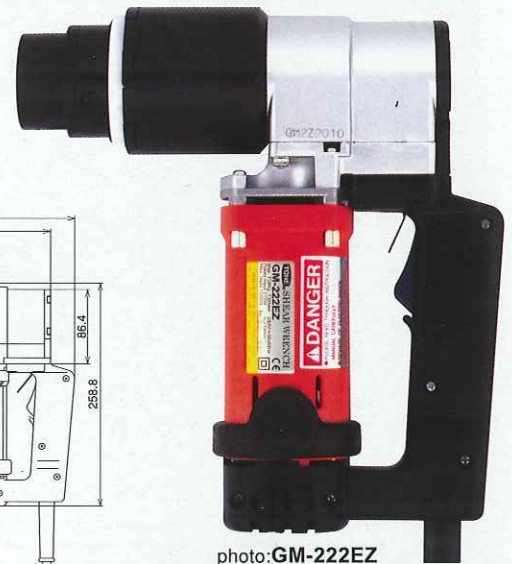
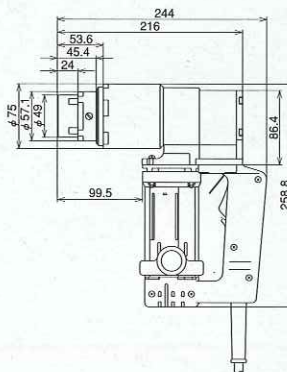

photo:GM-222EZ

GM-221HRZ / GM-222HRZ

Model	GM-221HRZ	GM-222HRZ
Frequency	50-60Hz	
Rated Voltage(Single Phase)	115V	230V
Max. Current	13A	6.5A
Rated Input Power	1400W	
Intermittent Operation (rated operating time / rated resting time)	2s/3s	
Rated Max. Torque	735N.m (542lbf.ft)	
No-Load Speed	18min ⁻¹ (rpm)	
Sound Pressure Level	87dB(A)	
Acoustic Power Level	98dB(A)	
Vibration Level	2.5m/s ² or below	
Adaptable Bolts Dia.	S10T	M16, M20, M22
	A325	5/8", 3/4", 7/8"
	A490	5/8", 3/4"
Weight (Main Body)	5.8kg(12.8lbs)	
Protection Class	□ (class II tool)	

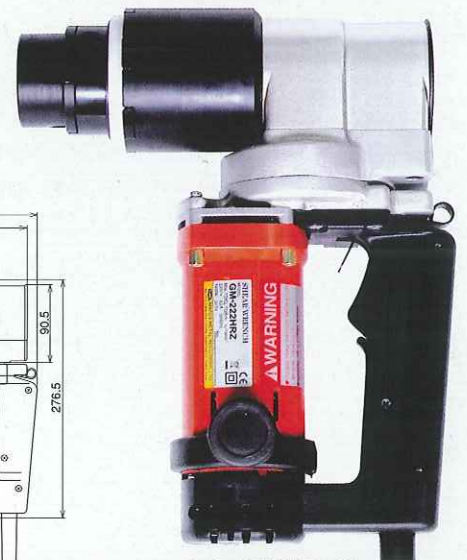
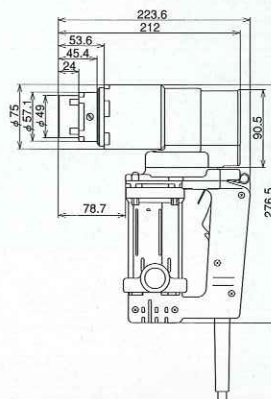

photo:GM-222HRZ

G SERIES SHEAR WRENCH

GH-241EZ / GH-242EZ

Model	GH-241EZ	GH-242EZ
Frequency	50-60Hz	
Rated Voltage(Single Phase)	115V	230V
Max. Current	11A	5.5A
Rated Input Power	1200W	
Intermittent Operation (rated operating time / rated resting time)	2s/3s	
Rated Max. Torque	950N.m (701bf.ft)	
No-Load Speed	10min ⁻¹ (rpm)	
Sound Pressure Level	87dB(A)	
Acoustic Power Level	98dB(A)	
Vibration Level	2.5m/s ² or below	
Adaptable Bolts Dia.	S10T	M16, M20, M22, M24
	A325	3/4", 7/8", 1"
	A490	3/4", 7/8"
Weight (Main Body)	6.2kg(13.7lbs)	
Protection Class	□ (class II tool)	

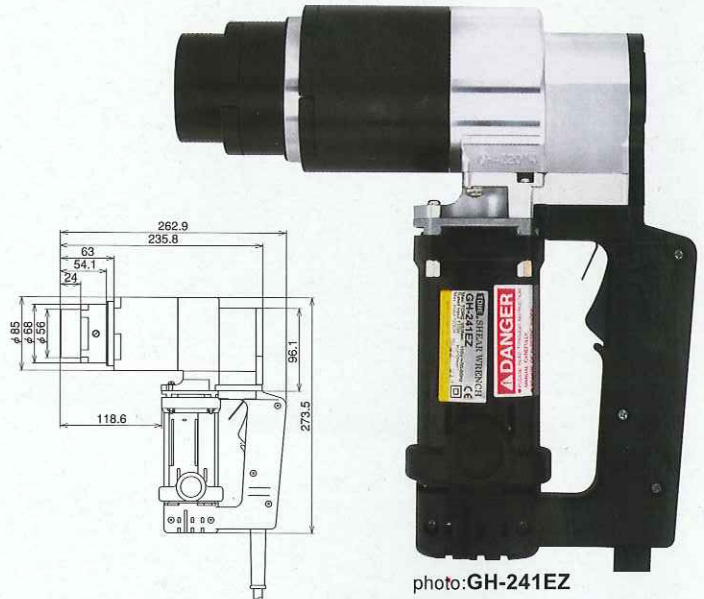

photo:GH-241EZ

GH-241HRZ / GH-242HRZ

Model	GH-241HRZ	GH-242HRZ
Frequency	50-60Hz	
Rated Voltage(Single Phase)	115V	230V
Max. Current	11A	5.5A
Rated Input Power	1200W	
Intermittent Operation (rated operating time / rated resting time)	2s/3s	
Rated Max. Torque	950N.m (701bf.ft)	
No-Load Speed	9min ⁻¹ (rpm)	
Sound Pressure Level	87dB(A)	
Acoustic Power Level	98dB(A)	
Vibration Level	2.5m/s ² or below	
Adaptable Bolts Dia.	S10T	M16, M20, M22, M24
	A325	3/4", 7/8", 1"
	A490	3/4", 7/8"
Weight (Main Body)	7.2kg(15.8lbs)	
Protection Class	□ (class II tool)	



photo:GH-241HRZ

GV-301EZ / GV-302EZ

Model	GV-301EZ	GV-302EZ
Frequency	50-60Hz	
Rated Voltage(Single Phase)	115V	230V
Max. Current	11A	5.5A
Rated Input Power	1200W	
Intermittent Operation (rated operating time / rated resting time)	2s/3s	
Rated Max. Torque	1900N.m (1402bf.ft)	
No-Load Speed	5min ⁻¹ (rpm)	
Sound Pressure Level	87dB(A)	
Acoustic Power Level	98dB(A)	
Vibration Level	2.5m/s ² or below	
Adaptable Bolts Dia.	S10T	M27, M30
	A325	1-1/8"
	A490	1-1/8"
Weight (Main Body)	6.7kg(14.8lbs)	
Protection Class	□ (class II tool)	

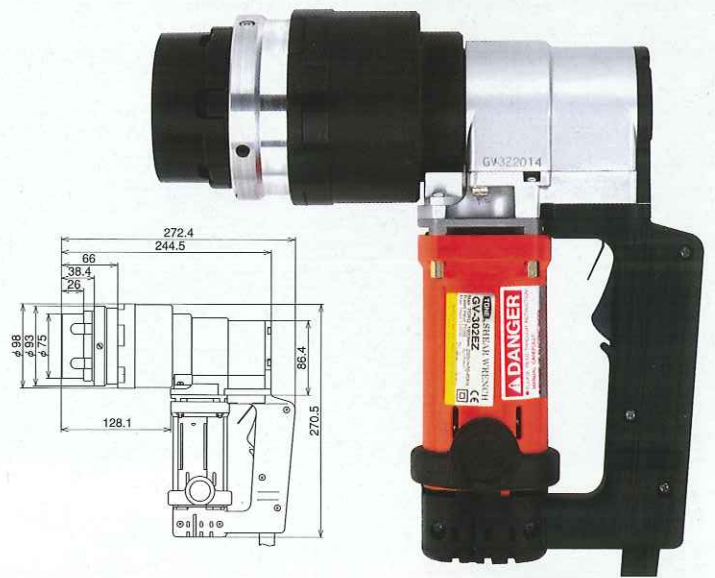

photo:GV-302EZ



www.tonetool.co.jp

Manufactured by

TONE MAEDA METAL INDUSTRIES, LTD.
OSAKA, JAPAN.



web site <http://www.tonetool.co.jp>
e-mail: overseas@tonetool.co.jp

Specifications and the design are subject to change without notice.



Our QMS & EMS have been approved by LRQA.

Your Distributor