

Transformerless (AC)
 Brush motor / Brushless motor
 Miniature screw / Precision screw / Machine screw
 2.6 - 6.0 mm

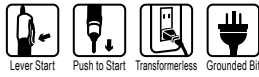

DLV7104/8104/8204 Series Non-CE



Features

The most popular models have been redesigned

- Equipped with bit grounding mechanism
- Long-life cam is utilized
- The clear plastic torque adjustment ring cover minimizes unintentional tampering of the preset torque
- The changeover switch enables operators to change forward/reverse rotation with a single hand
- The ergonomically designed grip can be held tightly to resist against tightening reaction force, resulting in reduced operator fatigue

Specifications

Model	Plug Shape: USA	Standard						High Torque		High Speed		
	Plug Shape: UK	DLV7124-MKE	DLV7134-MKE	DLV7144-MKE	DLV8124-MKE	DLV8134-MKE	DLV8144-MKE	DLV8154-MKE	DLV8224-MKE	DLV8234-MKE	DLV8244-MKE	
Electric Screwdriver	Starting Method	Lever Start						Push to Start				
	Input Voltage	230 V AC, 50/60 Hz										
	Torque Adjustment	Stepless										
	Torque (Nm)	0.25 - 0.75	0.5 - 1.7	1.2 - 3.0	0.25 - 0.75	0.5 - 1.7	1.2 - 3.0	2.0 - 4.5	0.35 - 0.7	0.5 - 1.7	1.2 - 3.0	
	[lbf-in]	[2.2 - 6.6]	[4.4 - 15.1]	[10.6 - 26.6]	[2.2 - 6.6]	[4.4 - 15.1]	[10.6 - 26.6]	[17.7 - 39.8]	[3.1 - 6.2]	[4.4 - 15.1]	[10.6 - 26.6]	
	Free Speed (min ⁻¹)	900		600	900		600	400	2000	1800	1100	
	Power Consumption (W)	35						45				
	Screw Size (mm)	Machine Screw	2.6 - 3.0	2.6 - 4.0	3.5 - 5.0	2.6 - 3.0	2.6 - 4.0	3.5 - 5.0	4.5 - 6.0	2.6 - 3.0	2.6 - 4.0	3.5 - 5.0
		Tapping Screw	2.3 - 3.0	2.3 - 3.5	3.0 - 4.0	2.3 - 3.0	2.3 - 3.5	3.0 - 4.0	4.5 - 5.0	2.3 - 3.0	2.3 - 3.5	3.0 - 4.0
	Mass (g [lbs])	720 [1.59]			710 [1.57]			910 [2.01]	710 [1.57]			
Bit Type	 unit: mm	For MKE		For MKH								
		USA		UK								

Please contact us for 5 mm bit type.

Standard Accessories

Model	MKE/MKH	8154-MKE/MKH	
Bit NK35	No.1 × 7 × 75	1	-
	No.2 × 7 × 75	1	1
	No.3 × 7 × 50	-	1
Spare Carbon Brush		2	
Suspension Bail		1	

Torque Diagrams (for reference)

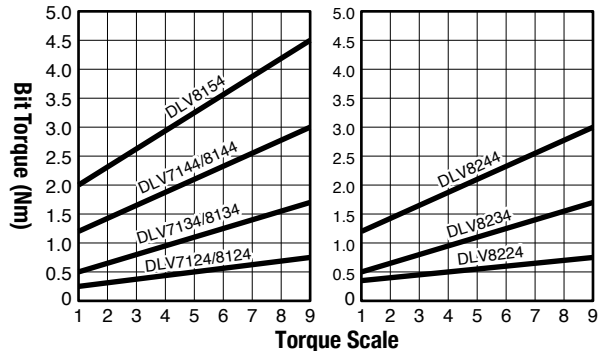

External Dimensions

•DLV7124 / 7134 / 7144

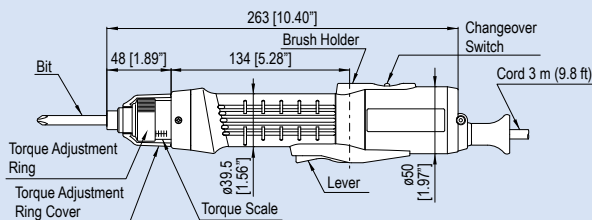

•DLV8154

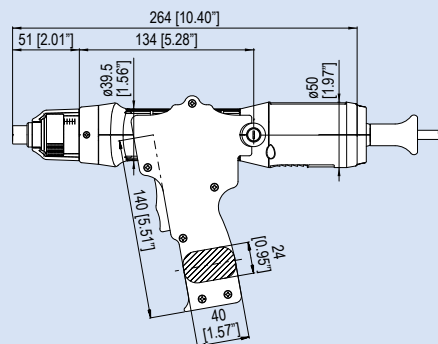

•DLV8124 / 8134 / 8144 / 8224 / 8234 / 8244

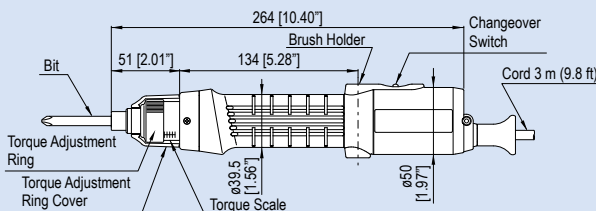

unit: mm [inch]